

Hostile environment luminaire series PFN ..., PFN-T16 ...

Design: Single luminaire, housing constructed of glass fibre reinforced grey polyester. The lower part of the luminaire is fixed to the top part with plastic screws. PFN series luminaires are double insulated, protection class II, dust tight and jet proof (IP65). With low loss ballasts (VVG), 230 V, 50 Hz, or electronic ballasts (EVG) 220-240 V, 0/50-60 Hz

Mounting: Luminaire suitable for ceiling mounting, horizontal or vertical wall mounting only possible in consultation with the manufacturer.

Special features: PFN series luminaires are double insulated, dust tight and jet proof.

Note: The seals for the lamp are made of material containing silicone.

PFN ...
For T26 lamps

PFN-T16 ...
For T16 lamps

Voltage: 230V/50Hz
Protection class: IP 65
Approvals:

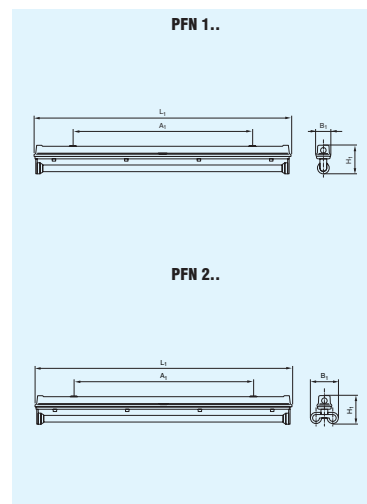

Model	Lamps	Dimens. [mm]				magnetic ballast Prod. code	electronic ballast Prod. code	dim. ballast (DALI) Prod. code
		L1	B1	H1	A1			
PFN 118	1xT26 18 W	654	62	130	450	0910165	0920165	
PFN 136	1xT26 36 W	1266	62	130	800	0910166	0920166	
PFN 158	1xT26 58 W	1566	62	130	1100	0910167	0920167	
PFN 218	2xT26 18 W	654	126	130	450	0910168	0920168	
PFN 236	2xT26 36 W	1266	126	130	800	0910169	0920169	
PFN 258	2xT26 58 W	1566	126	130	1100	0910170	0920170	
PFN-T16 128	1xT16 28 W	1205	62	125	800		0920625	
PFN-T16 135	1xT16 35 W	1505	62	125	1200		0920626	
PFN-T16 149	1xT16 49 W	1505	62	125	1200		0920629	
PFN-T16 154	1xT16 54 W	1205	62	125	800		0920630	
PFN-T16 180	1xT16 80 W	1505	62	125	1200		0920631	
PFN-T16 228	2xT16 28 W	1205	126	125	800		0920634	
PFN-T16 235	2xT16 35 W	1505	126	125	1200		0920635	
PFN-T16 249	2xT16 49 W	1505	126	125	1200		0920638	
PFN-T16 254	2xT16 54 W	1205	126	125	800		0920639	

Accessories

Model	Description	Prod. code
PFN-SRG-D26	Threaded ring socket PFN for 26mm lamp dia.	0070305
PFN-SRG-D38	Threaded ring socket PFN for lamp dia. 38 mm	0070009
PFN-SRG-D50	Threaded ring socket PFN for protective tube dia. 50 mm	0070097
PFNZR 136	Reflector for PFN 136, white	0201648
PFNZR 158 A	Reflector for PFN 158, aluminium	0201655
PFNZR 158	Reflector for PFN 158, white	0201649
PFNZR 236	Reflector for PFN 236, white	0201651
PFNZR 258 A	Reflector for PFN 258, aluminium	0201658
PFNZR 258	Reflector for PFN 258, white	0201652
SR 118	Protective tube for PFN .18, dia. 50, PMMA, w.threaded ring	0201009
SR 136 PC	Protective tube for PFN .36, dia. 50, PC, with threaded ring	0201448
SR 136	Protective tube for PFN .36, dia. 50, PMMA, w.threaded ring	0201010
SR 158 PC	Protective tube for PFN .58, dia. 50, PC, with threaded ring	0201449
SR 158	Protective tube for PFN .58, dia. 50, PMMA, w.threaded ring	0201011
SR-T16 128	Protective tube for PFN .28, dia. 38mm, PC, w. thr. rings	1201106
SR-T16 135	Protective tube for PFN .35, dia. 38mm, PC, w. thr. rings	1201107
SRD 136 OR	Triang. prot.tube dia. 50mm. refl., PFN 136, no thr. ring	0201441
SRD 136	Triang. prot. tube dia. 50 w. refl., PFN 136 w. thr. ring	1201441
SRD 158 OR	Triang. prot.tube dia. 50mm. refl., PFN 158, no thr. ring	0201103
SRD 158	Triang. prot. tube dia. 50 w. refl., PFN 158 w. thr. ring	1201103
SRD-T16 128	Triang. protective tube w. reflector, PFN 128, w. thr. ring	1201104
SRD-T16 135	Triang. protective tube w. reflector, PFN 135, w. thr. ring	1201105
ZIDVF 36/2/1,5/II	Through wiring for PFN, PFAG, PFAMI, Class II, 36W, 2X1.5mm ²	0110226
ZIDVF 36/4/1,5/II	Through wiring for PFN, PFAG, PFAMI, Class II, 36W, 4X1.5mm ²	0110228
ZIDVF 58/2/1,5/II	Through wiring for PFN, PFAG, PFAMI, Class II, 58W, 2X1.5mm ²	0110227
ZIDVF 58/4/1,5/II	Through wiring for PFN, PFAG, PFAMI, Class II, 58W, 4X1.5mm ²	0110229
ZVS-PK	Power factor cabling kit for surface & recessed luminaires	0207799



